

CASTLOADERS

800 ECO

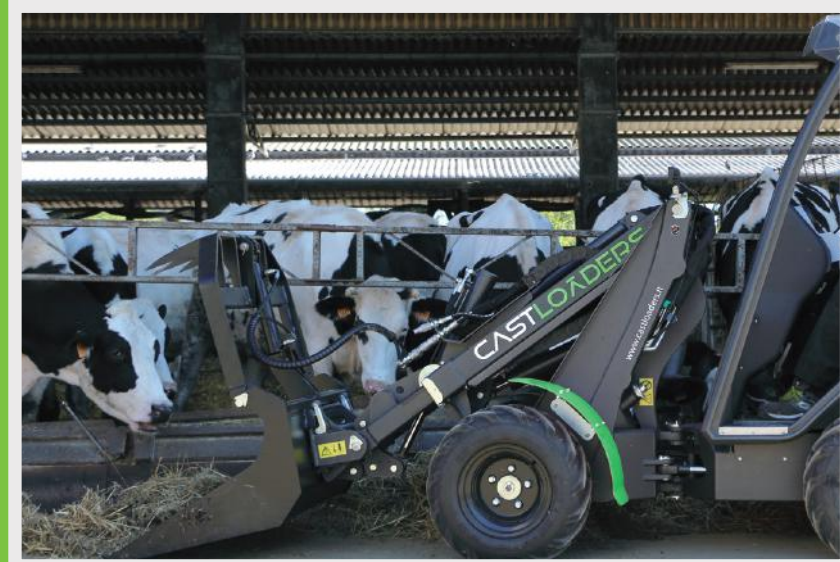

800 ECO

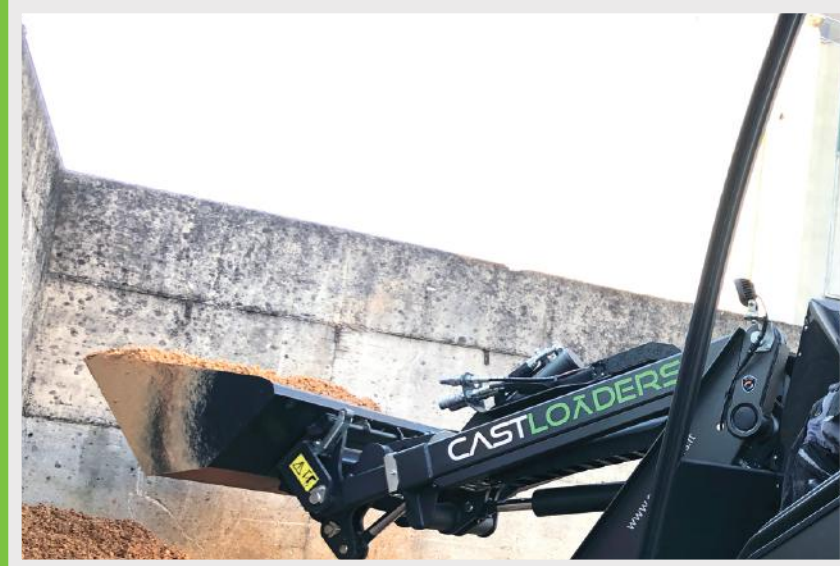

DIMENSIONS AND LOADING DIAGRAMS

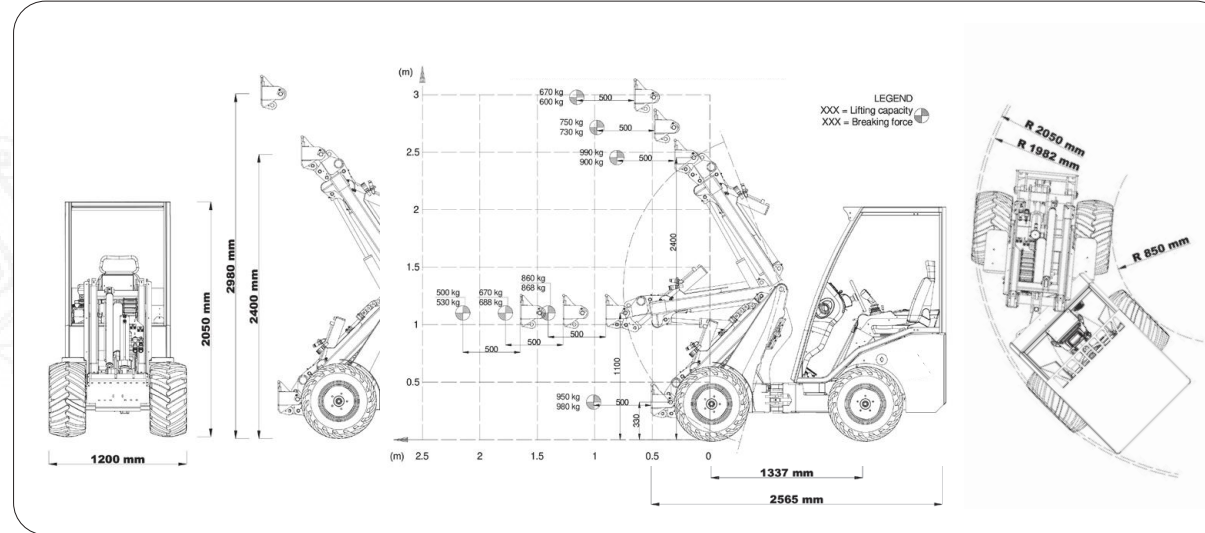

WHEELS

SKID	ALL TRAC	TRACTOR	TURF
23X8.50-12 23X10.50-12 26X12.00-12	8PR 300/60X12	23X8.50-12 23X10.50-12 26X12.00-12	23X8.50-12 23X10.50-12 24X13.00-12 26X12.00-12 26.5X14.00-12

FEATURES

LIFTING CAPACITY	ELECTRIC ENGINE	POWER	SPEED	HYDRAULIC SYSTEM	BOOM HEIGHT
950 Kg	2 Permanent magnets 48 Volt / 210 Ah	15 Kw	12 Km/h @ 26X12.00-12	25 l/min	2980 mm

CASTGROUP
 WWW.CASTLOADERS.IT

CAST GROUP SRL
 Via A. Meucci, 18 I-30035 MIRANO VE
 ph. +39041 5701827 fx +39041 5726786
 info@cast-group.it

LEAF_800 ECO_ENG_05/2022_A000000016

Data contained in this document is subject to change without notice and/or notification. Cast Group reserves the right to modify its products without obligation to communications. The images in this document are the only a demonstrative purpose.



ZERO EMISSION

800 ECO

HYDROSTATIC FULL ELECTRIC LOADER • ECO FRIENDLY • ZERO EMISSION • ENERGY SAVING • TELESCOPIC

CASTLOADERS
 MADE IN ITALY

EN





800 ECO

Technology and innovation enclosed in an extremely versatile machine with extraordinary maneuverability and respectable load capacity. The generous electric engine with two permanent magnets is very quiet and the battery offers an autonomy of up to 4 / 4.5 hours depending on the intensity of use. The 14- function Joystick is standard.



Features that make the difference.

- Lifting capacity 950 Kg
- Engine power 15 Kw
- Hydraulic system 25 l / min
- Telescopic boom height 2980 mm
- Selflevelling system
- Electric differential lock
- 14- functions Joystick

Cast 800 ECO is available with an electrolyte traction battery. Features: 48 Volt / 210 Ah, excellent autonomy even in intense work conditions, low weight and extended life cycle. The average charging times are about 6/8 hours with a low battery. Cast 800 ECO is also available with a fast-charging lithium battery.

For optimal life cycle, it is recommended to recharge the battery when it is completely discharged.

STEER ADJ

Tilt adjustment of the steering column.

ERGONOMIC SEAT

Ergonomic and adjustable seat with safety belt and armrests.

TELESCOPIC

Telescopic boom equipped of selflevelling system with maximum height up to 2980 mm.



SILENT BLOCK

800 ECO

It is equipped as standard with a device that allows greater driving comfort: the Silent Block. This device has been designed to cushion shocks and jerks while driving, especially in rough terrain situations, improving grip and stability.



- Agriculture
- Breeding
- Green maintenance
- Building
- Road maintenance



Variable flow hydraulic pump.

- Less effort
- Less wear
- Lower consumption

Variable flow: a condition of greater power with minimal effort.

The hydraulic pump is equipped with a variable set-up that allows to exploit the power used in an optimal way by limiting the effort with an increase in performance when the machine is put to the test. The reduction in consumption is guaranteed and at the same time also the wear of the engine and transmission organs are minor with resulting benefit for the life of the machine.